

# PILOT, LOGIC & SPECIALIST VALVES SPECIALIST VALVES



## Specification

Model	KP100014	KP100094	KP010444	KP010464	KP100354	KP000744	KP2005
Fluid	Air (to be filtered by 50µm filter element)						
Port	G1/8"		G1/4"			G1/8"	M5
Working Pressure	0.2 - 1MPa (30 - 145psi)				0.3 - 1MPa (45 - 145psi)	0.2 - 1MPa (30 - 145psi)	0.3 - 0.8MPa (45 - 116psi)
Actuating Pressure	-	-	0.3 - 1MPa (45 - 145psi)	0.2 - 1MPa (30 - 145psi)	0.3 - 1MPa (45 - 145psi)	-	-
Temperature	0°C to +60°C						
Material of Body	Aluminium						
Material of Spring	Stainless Steel						
Material of Seals	NBR						
Material of Internal Components	Brass						
Material of Spool	-	-	Nickel Plated Aluminium				-
Time Regulating range	0 - 15 sec				-	0 to 15 sec	-

## Symbols

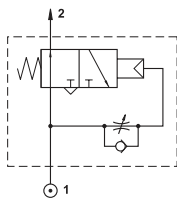

Impulse Valve, NO

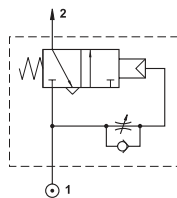

Impulse Valve, NC

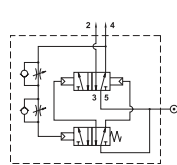

Oscillating Valve,  
Continuing Cycle

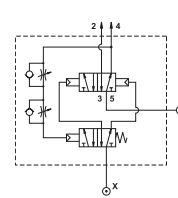

Oscillating Valve,  
Pneumatically Piloted

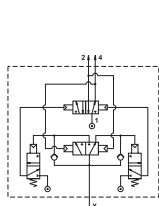

Flip Flop Valve,  
Pneumatically Piloted

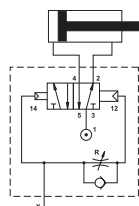

High Flow Pneumatic Timer  
for Automatic Return

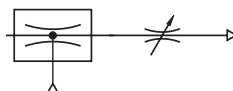

Vacuum Driven  
Liquid Sprayer

# PILOT, LOGIC & SPECIALIST VALVES



## SPECIALIST VALVES

### Dimensions Impulse Valves

Model:

- **KP100014** Normally Open
- **KP100094** Normally Closed

### Valve Operation

#### Normally Open

The Normally Open Valve produces an adjustable impulse of fixed duration by adjusting screw (R). When a signal is applied from a three way valve and maintained at port 1 the impulse generator is activated and will generate an impulse period which was pre-set by (R). If the signal is interrupted the duration of the impulse is terminated. To repeat the cycle the pilot signal must be exhausted and applied again.

#### Normally Closed

With the Normally Closed Valve, if air is supplied at port 1, it lets the air go out from port 2 when the adjustable time (pre-set by R) has elapsed. The air flow can then be interrupted by removing the air supply from port 1. The difference from the Normally Open version (KP100014), is that the screw R adjusts the dwell time and not the duration of the air impulse.

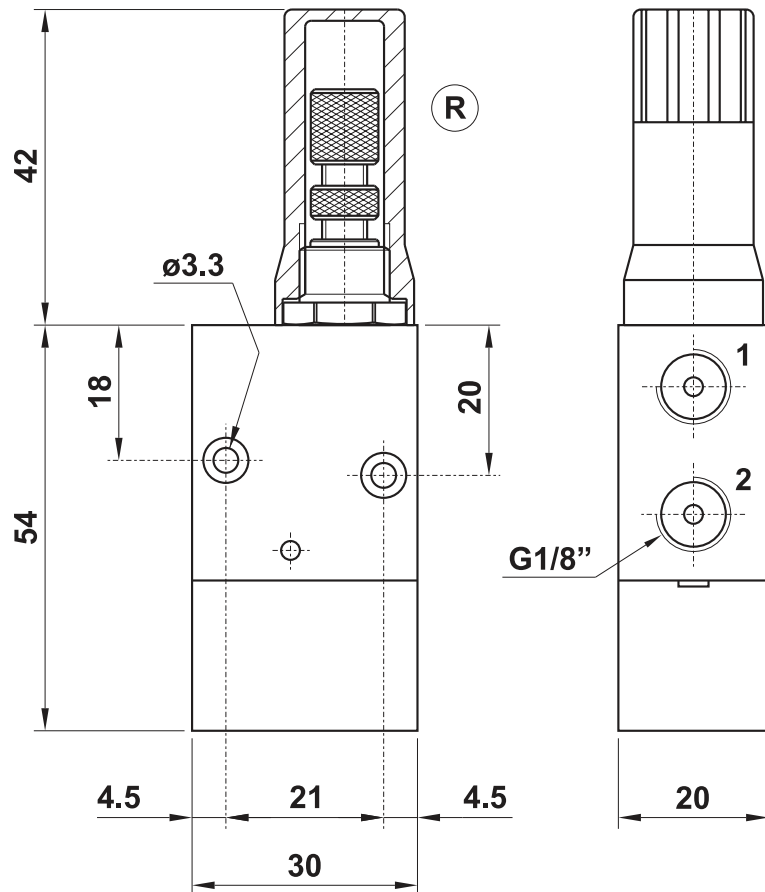

# PILOT, LOGIC & SPECIALIST VALVES TWO HAND SAFETY UNIT



## Specification

### Two Hand Pre-assembled Unit

Model	KP081564
Fluid	Air (to be filtered by 50µm filter element)
Port	4mm Push-in
Working Pressure	0.3 – 0.8MPa (45 – 116psi)
Maximum Flow Rate	100 Nl/min
Temperature	-10°C to +60°C
Delay between the two actuating signals	$\Delta t < 0.5$ s



### Two Hand Base Unit

Model	KPBU081564
Fluid	Air (to be filtered by 50µm filter element)
Port	G1/8"
Working Pressure	0.3 – 0.8MPa (45 – 116psi)
Maximum Flow Rate	100 Nl/min
Temperature	-10°C to +60°C
Delay between the two actuating signals	$\Delta t < 0.5$ s
Material of Body	Aluminium
Material of Seals	NBR
Material of Internal Components	Brass
Material of Spring	Stainless Steel



## Symbols

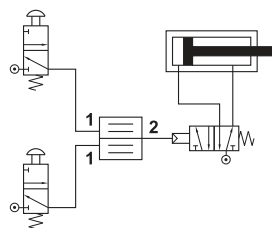

Application Sketch

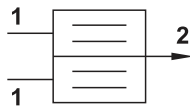

Logic Symbol

## VALVES TWO HAND SAFETY

### UNIT

Dimensions  
Two Hand  
Pre-assembled Unit

Model:

- **KP081564**

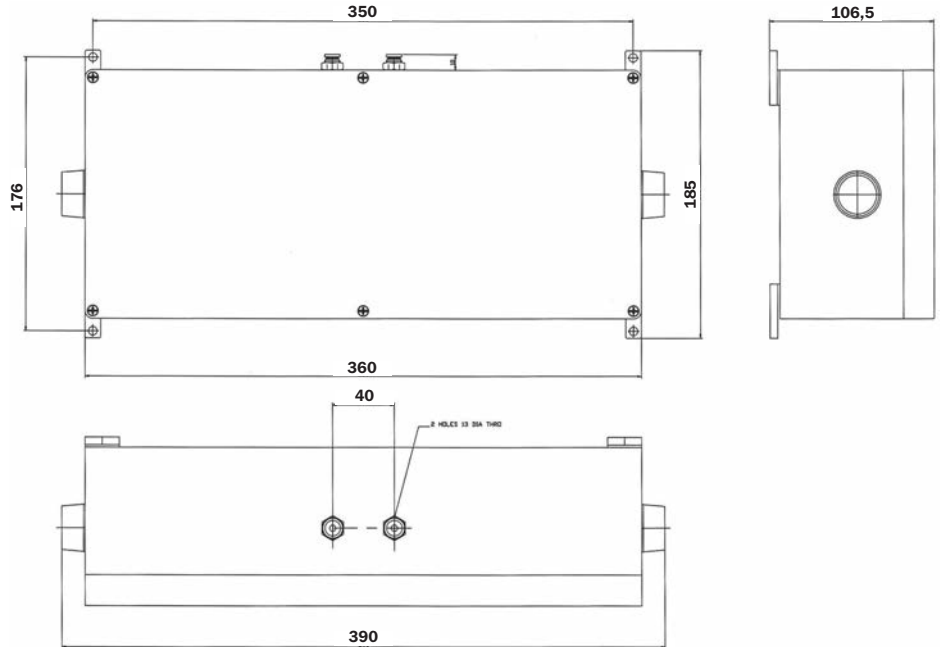

### Valve Operation

This fully pre-assembled unit comes ready to use, simply connect the unit to the air supply. For full details on the base unit see part number KPBU081564.

Dimensions  
Two Hand Base Unit

Model:

- **KPBU081564**

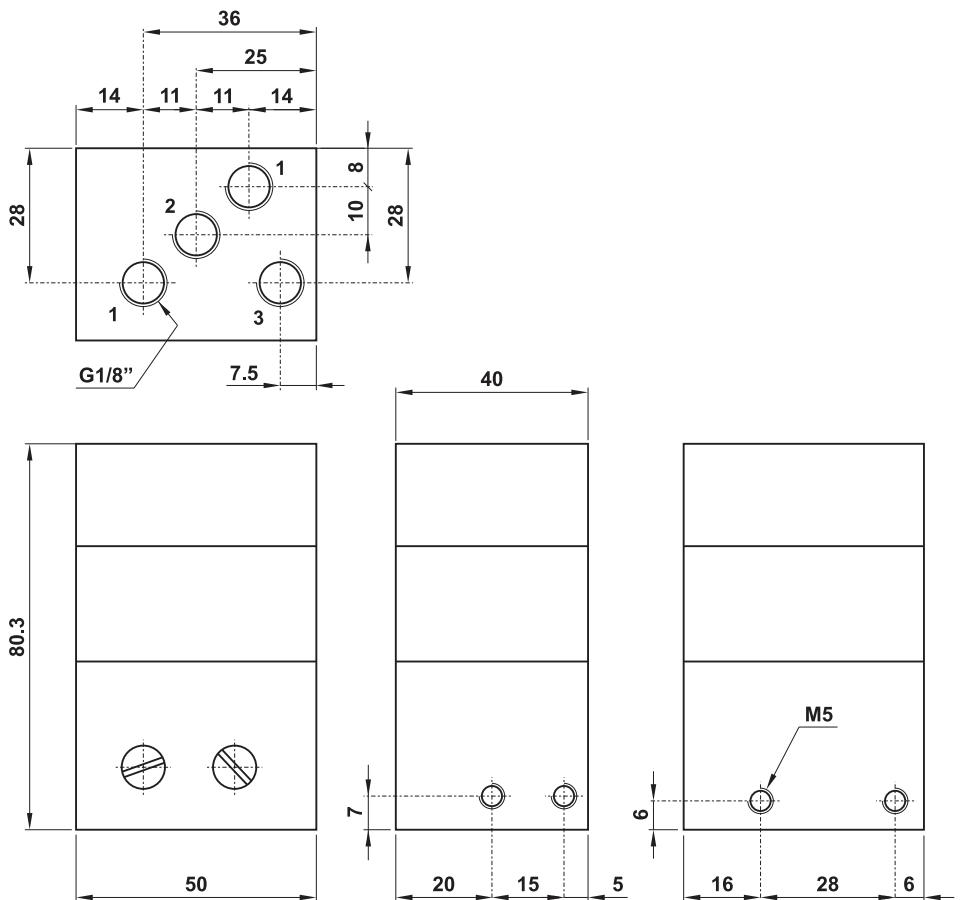

### Valve Operation

The base unit is used to pilot high-flow directional control valves connected to machines which have a high risk of injuries to the operator's hands. The machine operator must simultaneously operate, in a safe area, two 3 way manual valves for correct operation. The safety valve will ignore a single depression of one of the manual valves. To repeat the cycle both pilot signals must be exhausted and the manual valves simultaneously actuated again.

The signal elaborator is sold with certification (compliant to Machinery Directive 2006/42/EC and to Norm UNI EN 574-1:2008 and EN 574:1996 + A1:2008 type 3A).